

MBD - MANUAL BAG DUMP CONFIGURATOR

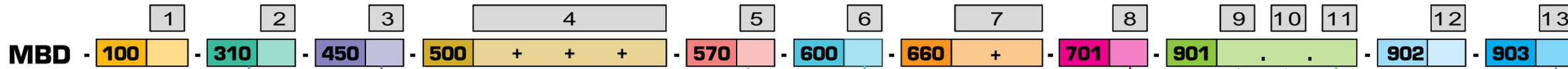

CONFIGURATION 100	
1	With dust tight emptying box V Without dust tight emptying box X
STORAGE VOLUME 310	
2	3 ft ³ A 5 ft ³ B
FILTER 450	
3	Pleated cartridge filter element (9.15 ft ² filtering area / each) B Sock type filter element E
INSTRUMENTS 500	
4	Solids level sensor - vibrating rod type A Door closing safety switch E Differential pressure indicator (without signal) F Differential pressure indicator (with signal) G
FANS 570	
5	1.5 HP, Centrifugal fan (MBD) A
EXTRACTOR / VIBRATOR 600	
6	Air actuated impactor J Electrical motovibrator K
PROCESS ACCESSORIES 660	
7	Manual blast gate N Manual pressure regulator O

903 CERTIFICATION/CLASSIFICATION		
B	Class 2, division 2	13
C	Class 1, division 1	
G	Class 2, division 1	
902 CONTROL PANEL		
F	Local control panel	12
I	Equipment and instruments prewired to the control panel provided by CON-V-AIR	
J	Control panel provided by others	
901 MATERIAL / FINISH / COATING		
CH	Glass bead finish	11
CI	Mill finish	
CJ	#4 polish on welds in contact with the product	
CK	EC1 epoxy coating system	10
CL	FC1 FDA epoxy coating system	
CE	Carbon steel construction	9
CF	304L stainless steel construction	
CG	316 stainless steel construction	
701 ELECTRICAL POWER		
A	380V/3/50Hz	8
B	460V/3/50Hz	
C	575V/3/50Hz	
E	120V/1/50Hz	

000 : Section number Letters : Option code + : Multiple options . : Single option Ø : Symbol to enter if no option selected

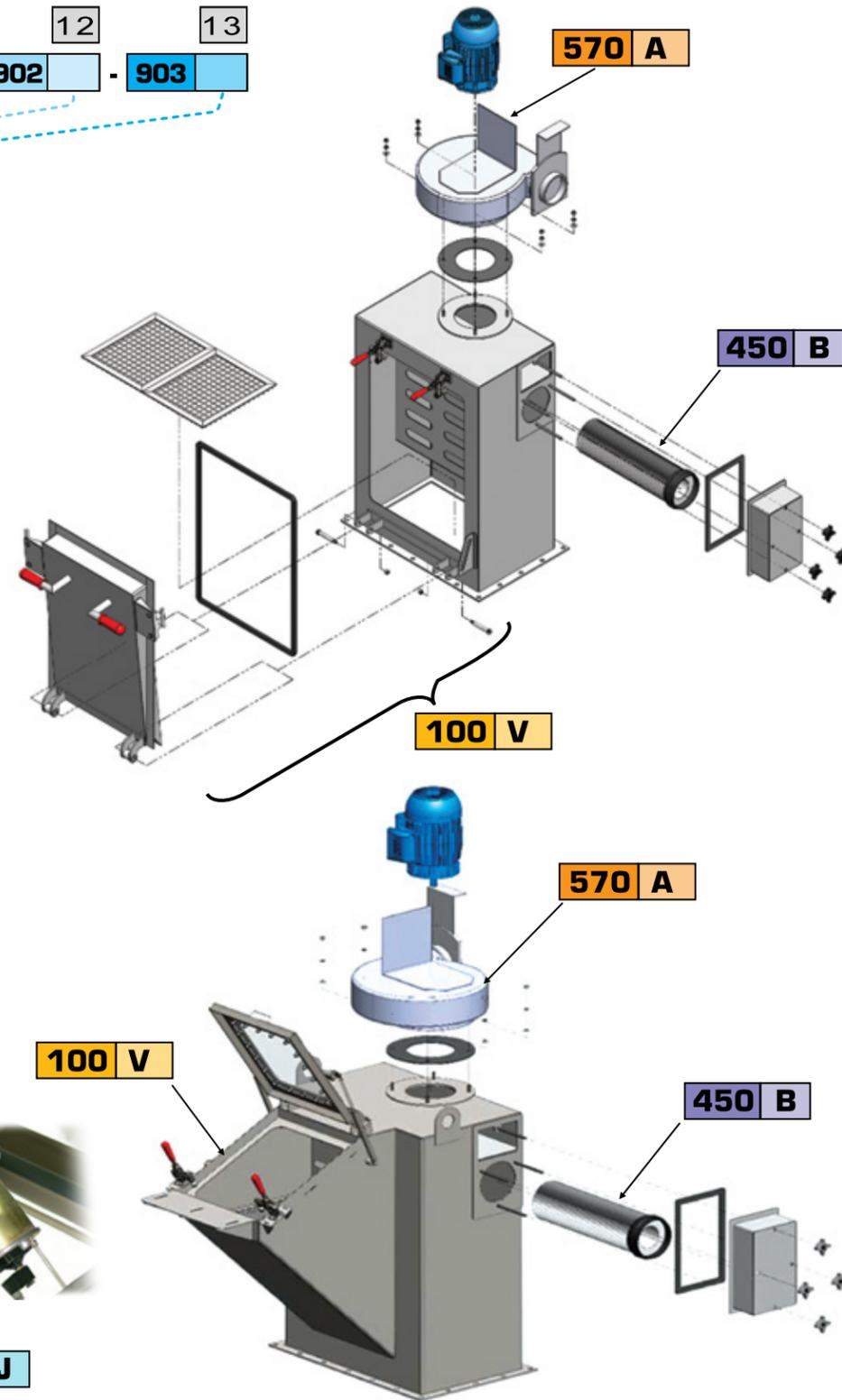

MBD - MANUAL BAG DUMP CONFIGURATOR

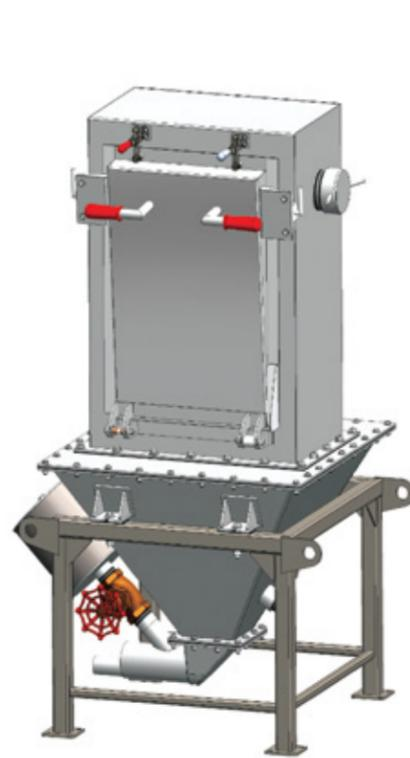

PCS - PNEUMATIC CONVEYING SYSTEM



DIS - DIRECT INJECTION SYSTEM



IIS - INDIRECT INJECTION SYSTEM

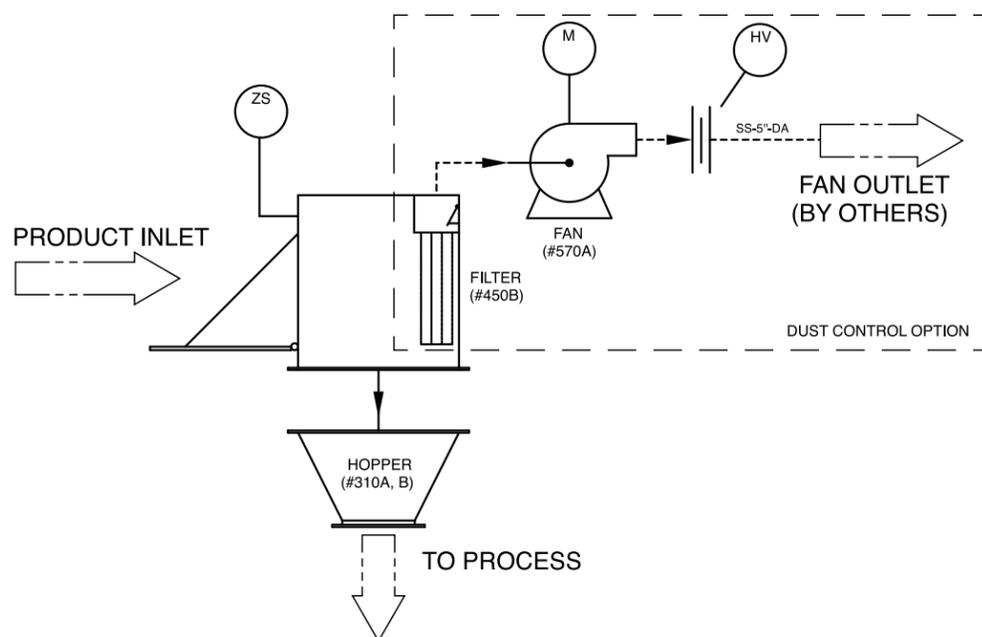
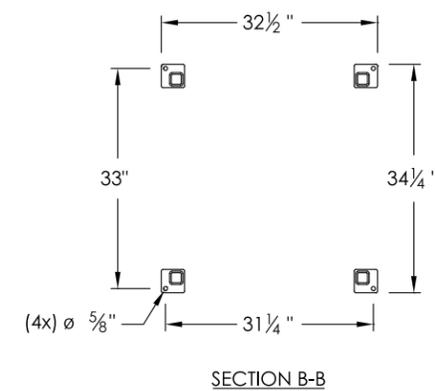
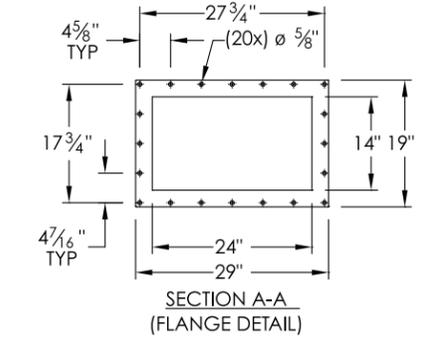
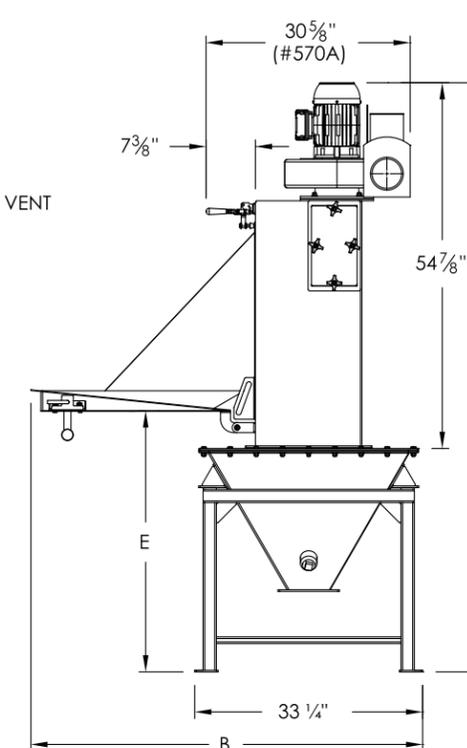
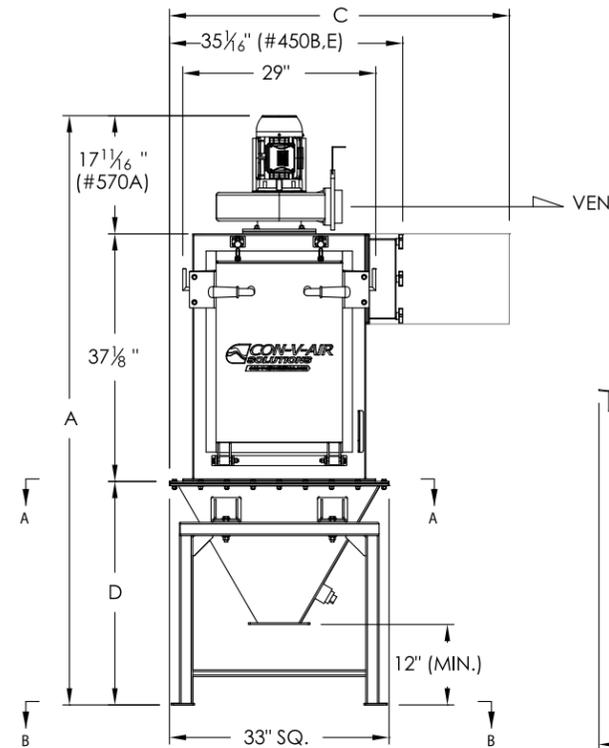

	ADDITIONAL OPTIONS	CONFIGURATION #	MANUAL BAG DUMP STATION DIMENSIONS												TOTAL CONSUMPTION			WEIGHT	
			"A"		"B"		"C"		"D"		"E"		"F"		AIR	ELECT.	TOTAL	lbs	kg
			in.	mm	in.	mm	in.	mm	in.	mm	in.	mm	in.	mm	CFM	PSI	HP		
W/O DUST TIGHT EMPTYING BOX (WHEN EMPTYING BAG)	- 3 ft ³ HOPPER - ELECTRIC VIBRATOR	#MBD-100V-310A-450B-570A-600A-660N	83.63	2124	52	1320.8	51	1295	28.75	730	34.25	870	72.00	1829	-	-	0.13	376	171
	- 5 ft ³ HOPPER - PNEUMATIC VIBRATOR	#MBD-100V-310B-450B-570A-600D-660N	85.63	2175	59	1499	51	1295	30.75	781	36.25	921	76.50	1943	6	60	-	437	199
	- WITHOUT HOPPER	#MBD-100V-3109-450B-570A-6009-660N	54.88	1394	51.25	1302	49	1245	0	0	5.50	140	57.75	1467	-	-	0.13	296	135
W/O DUST TIGHT EMPTYING BOX (WHEN EMPTYING BAG)	- 3 ft ³ HOPPER - ELECTRIC VIBRATOR	#MBD-100V-310A-600A	65.88	1673	52.00	1321	29.00	737	28.75	730	34.25	870	53.88	1368	-	-	0.13	321	146
	- 5 ft ³ HOPPER - PNEUMATIC VIBRATOR	#MBD-100V-310B-600D	67.88	1724	59.00	1499	33.00	838	30.75	781	36.25	921	55.88	1419	6	60	-	391	178
	- WITHOUT HOPPER	#MBD-100V	37.13	943	51.25	1302	29.00	737	0	0	5.50	140	37.13	943	-	-	0.13	230	105
W/ DUST TIGHT EMPTYING BOX (WHEN EMPTYING BAG)	- 3 ft ³ HOPPER - ELECTRIC VIBRATOR	#MBD-100X-310A-450B-570A-600A-660N	83.63	2124	52	1320.8	46.75	1187	28.75	730	34.25	870	72.00	1829	-	-	0.13	376	171
	- 5 ft ³ HOPPER - PNEUMATIC VIBRATOR	#MBD-100X-310B-450B-570A-600D-660N	85.63	2175	59	1499	46.75	1187	30.75	781	36.25	921	76.50	1943	6	60	-	437	199
	- WITHOUT HOPPER	#MBD-100X-3109-450B-570A-6009-660N	54.88	1394	51.25	1302	44.75	1137	0	0	5.50	140	57.75	1467	-	-	0.13	296	135
W/ DUST TIGHT EMPTYING BOX (WHEN EMPTYING BAG)	- 3 ft ³ HOPPER - ELECTRIC VIBRATOR	#MBD-100X-310A-600A	65.88	1673	52.00	1321	24.75	629	28.75	730	34.25	870	53.88	1368	-	-	0.13	321	146
	- 5 ft ³ HOPPER - PNEUMATIC VIBRATOR	#MBD-100X-310B-600D	67.88	1724	59.00	1499	28.75	730	30.75	781	36.25	921	55.88	1419	6	60	-	391	178
	- WITHOUT HOPPER	#MBD-100X	37.13	943	51.25	1302	24.75	629	0	0	5.50	140	37.13	943	-	-	0.13	230	105