

SFX - CONFIGURATEUR ASPIRATEUR SIFFLUX

SFX - Capacité de SIFFLUX			
Distance [pi]	Dimension [po]	Débit [lb / min.]	Ampérage [A]
15	1-1/2	10	13.8
	2	15	13.7
25	1-1/2	8	13.8
	2	12	13.7

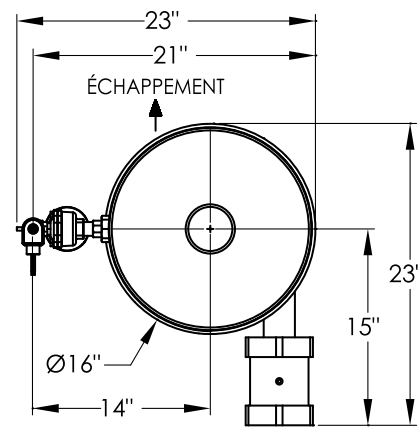

ENTRÉE DE PRODUIT
Ø2" FNPT

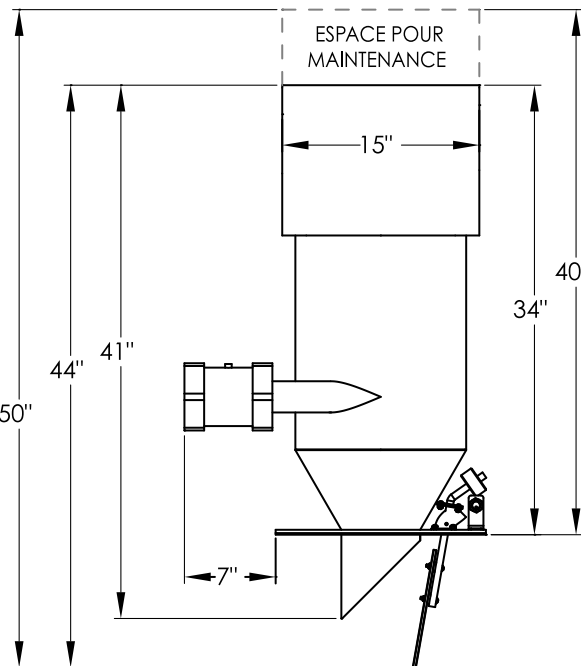
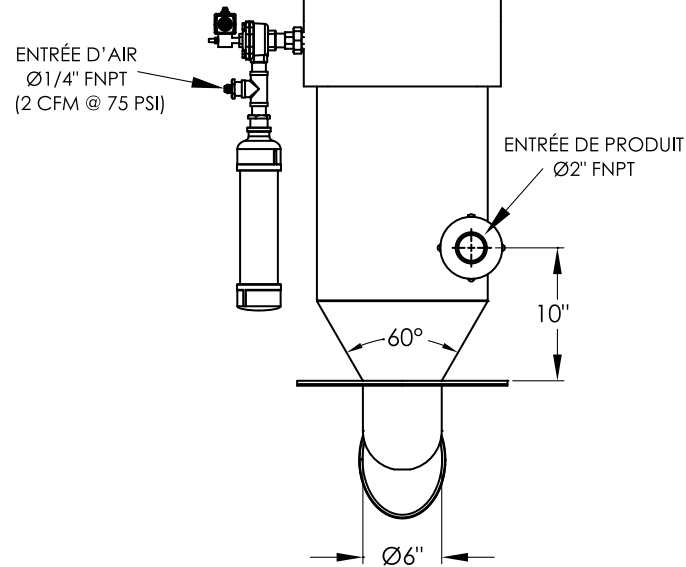

Contrepoids



Capot
accoustique

Ensemble de
nettoyage des
cartouches par
pulsation d'air

Entrée
de produit

Sortie de produit

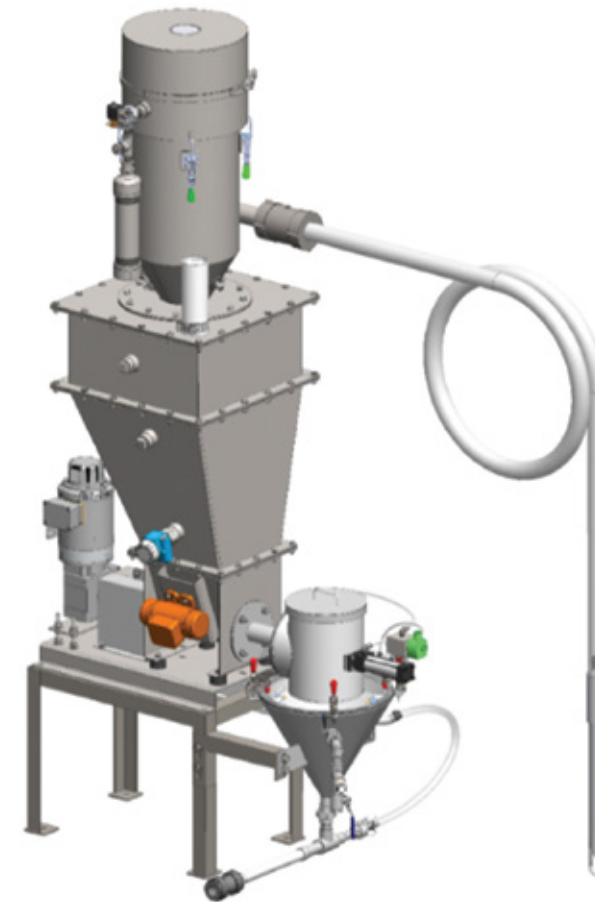
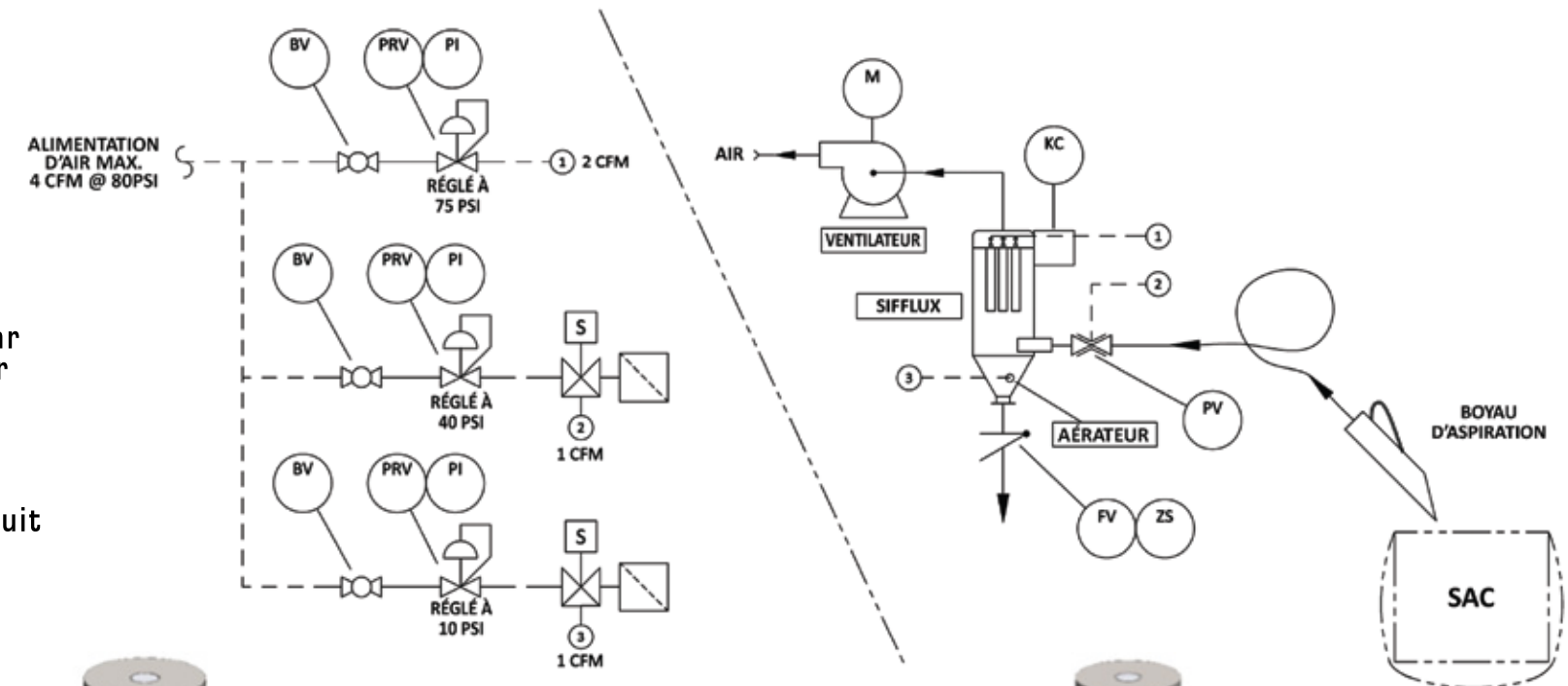

Système d'injection directe à concentration variable

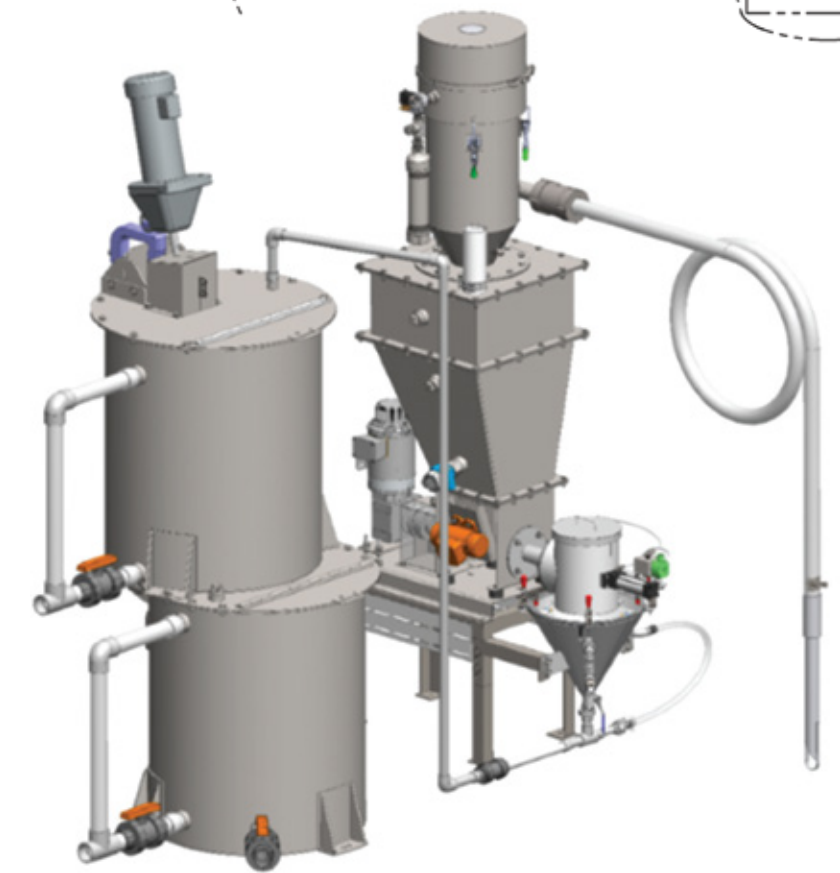

Système de polymère